



Batteries



42 Months Warranty*

*for PRIVATE passenger vehicle use, subject to terms and conditions

PART NUMBER	X56CMF	
CHARACTERISTIC	Lead-Acid Sealed Maintenance Free	
GROUP SIZE	A46	
CASE AND LID	Material	Polypropylene (PP)
	Handle	1-pc PP handle
	Case Colour	Black Casing
	Lid Colour	Red Lid
	Ledge / Hold-down	Recessed ledge on all sides
	Vent	Centralized venting

DIMENSIONAL SPECIFICATIONS

OVERALL DIMENSIONS	METRIC (mm)
LENGTH	233
WIDTH	171
HEIGHT (bottom to top cover)	182
TOTAL HEIGHT (bottom to top of terminal)	203
NOMINAL WEIGHT	15.72 kg

TERMINAL DATA	POSITIVE	NEGATIVE
TYPE	SAE	SAE
TERMINAL HEIGHT (mm)	18.5±1.50	18.5±1.50
BOTTOM DIAMETER (mm)	19.5+0/-0.3	17.5+0/-0.3
TAPER	1:9	1:9
POLARITY		

TECHNICAL SPECIFICATIONS

COLD CRANKING AMPS (CCA)	640 CCA
	Test reference: AS60095.1: 2022 Rated CCA DCH at 18°C for 30 sec
CAPACITY (RC)	115 mins
	Test reference: AS60095.1: 2022 25 Amps DCH at 10.5 V cut-off voltage

AMPERE-HOUR (20-HOUR CAPACITY)	64 AH
	Test reference: AS60095.1: 2022
	Rated AH DCH at 10.5 V cut-off
PLATE DESIGN	Lead-Calcium Alloy Full Frame Plate Design
ELECTROLYTE	36% H ₂ SO ₄ at 15°C

TOP VIEW

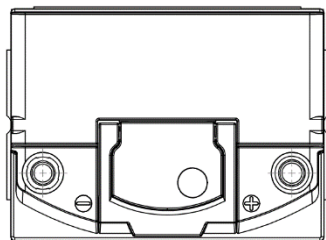

FRONT VIEW

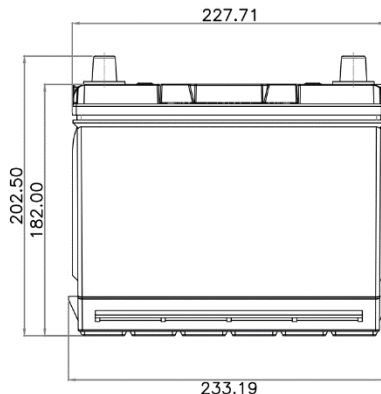

SIDE VIEW

